

# EZT<sup>®</sup>

Zero Turn Hydrostatic Transaxle

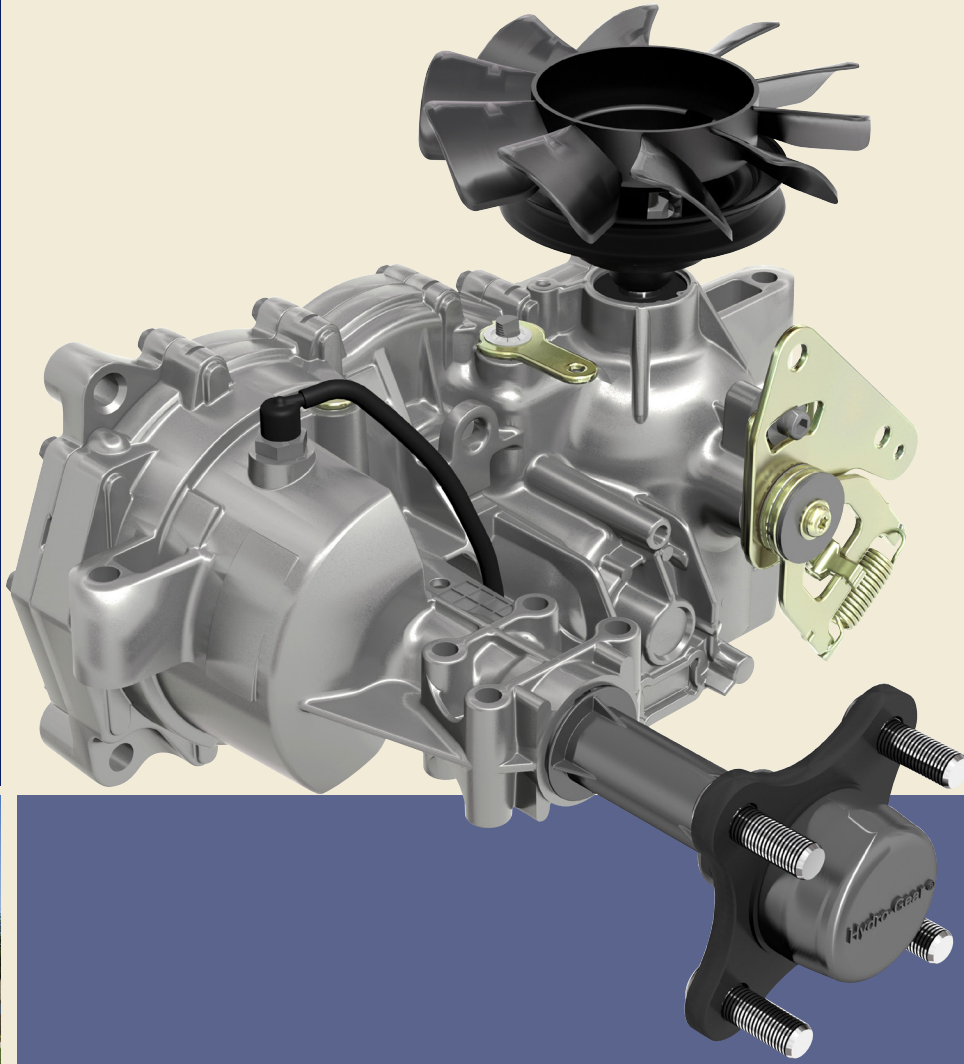

FORWARD MOTION THROUGH FORWARD THINKING<sup>®</sup>

 **HYDRO-GEAR<sup>®</sup>**  
FORWARD MOTION THROUGH FORWARD THINKING

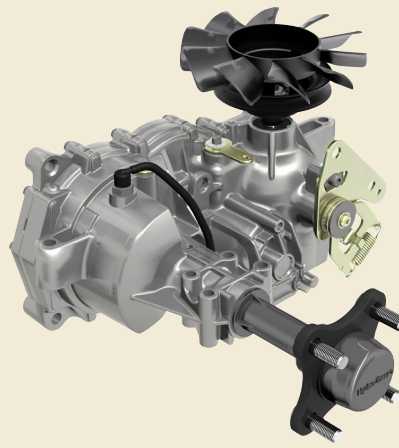

- Factory pre-set neutral
- Bypass mechanism
- Speed and directional control
- Return to Neutral option
- Several fan and pulley kit options
- Belt deflector option
- Industry leading warranty and service support



| SPECIFICATIONS                    | EZT        |                            |
|-----------------------------------|------------|----------------------------|
|                                   | ZC         |                            |
| Overall Transaxle Reduction       | 19.2:1     |                            |
| <b>Input Speeds</b>               |            |                            |
| Maximum Hi-Idle [No Load]         | rpm        | 3000                       |
| Minimum [Loaded]                  | rpm        | 1800                       |
| <b>Output Torque</b>              |            |                            |
| Continuous                        | lb-ft [Nm] | 115 [155]                  |
| Intermittent                      | lb-ft [Nm] | 150 [203]                  |
| <b>Weight on Tires (per unit)</b> |            |                            |
| Maximum with 18" tires            | lb [kg]    | 340 [154]                  |
| <b>Axle Shaft Diameter</b>        | in [mm]    | 1.00 [25.4]                |
| <b>Axle Shaft End Options</b>     | Type:      | Two Flats or 4-Bolt Flange |
| <b>Parking Brake Type</b>         |            | External Cog or Disc       |
| <b>Weight of Unit</b>             | lb [kg]    | 29 [13]                    |

Specifications subject to change without notice.

BLN-0052  
03/2012



A World Leader in Hydrostatic Transaxles \* Axial Piston Pumps & Motors \* LSHT Wheel Motors \* Electric L&G Systems  
1411 South Hamilton Street \* Sullivan, IL 61951 \* Phone (217) 728-2581 \* Fax (217) 728-7665 \* www.hydro-gear.com